

ENDON[®]

PL-LEDG9 Range- 2 light wall brackets.

INSTRUCTION MANUAL

Safety Warnings

These products are only suitable for connection to a 240V~50Hz supply in accordance with current IEE wiring Regulations and should be installed in accordance with local Building Regulations and are for Domestic wall use only. They are not suitable for bathroom use.

The light fittings should be connected to a lighting circuit protected by a 5 amp fuse (or a 6 amp miniature circuit breaker).

If in doubt we recommend you contact a qualified electrician. Before installing your light fitting always:

Switch off the mains supply and remove the appropriate fuse or switch off the appropriate circuit breaker before commencing installation.

Ensure that no one else has access that would enable the supply to be inadvertently reconnected.

Never fit bulbs of a higher wattage or of a type other than those specified on the label as this may cause overheating and damage the fitting.

These fittings should only be used with G9 led bulbs (as supplied) and, as with all led's, we recommend that you do not stare into the (led) beam.

Be careful during handling and maintenance to avoid breakage or damage to the fitting.

The bulbs become hot during use so please switch off and allow 10 minutes to cool before adjusting, replacing bulbs or cleaning the fitting.

Clean with a dry cloth only. Do not use liquid or abrasive cleaners on this product.

If any modification is made it will invalidate the warranty and may render the product unsafe.

Before you start

Please read these instructions carefully before fitting your new light and retain for reference.

Make sure that there are no pipes or cables beneath the mounting surface.

Check the packaging and make sure that you have all the required parts.

Follow each assembly step in order to prevent incorrect assembly.

Make sure all screws / nuts, including electrical connections etc are fully tightened before use.

LED bulbs cannot (generally) be controlled by a dimmer.

The Light pack contains:

Light fitting and mounting bracket.

Terminal connection block(s).

G9 led bulbs

The following tools may be required:

Selection of cross and flat head screwdrivers.

Electric drill and assorted drill bits.

Wire strippers.

These assembly diagrams are intended as a guide – if in doubt consult a qualified electrician.

Diagram A

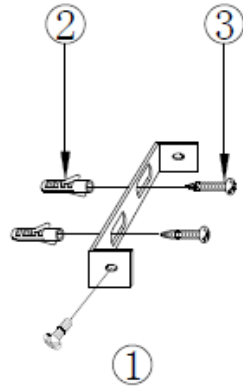
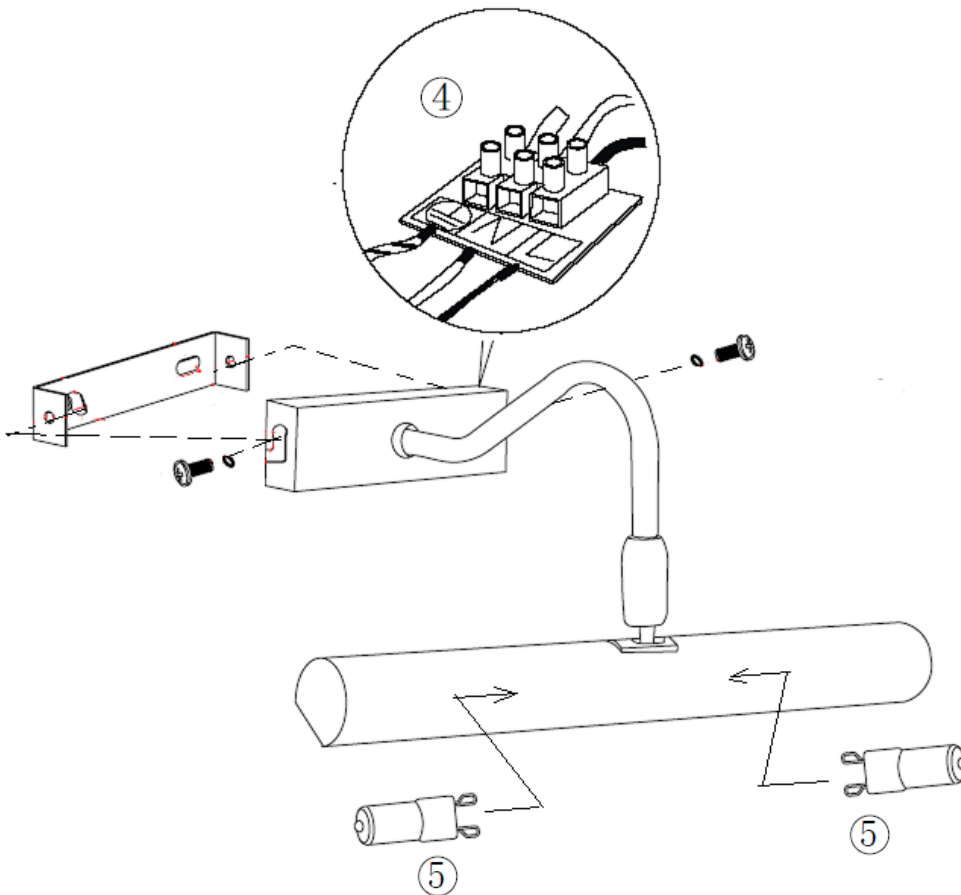

Diagram B



Wiring Details

HOUSEHOLD SUPPLY

SWITCHED LIVE L

EARTH (GREEN/YELLOW SLEEVED COPPER)

NEUTRAL N

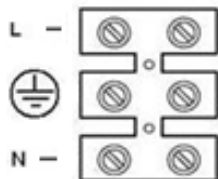

LIGHTFITTING

BROWN or LABELLED - L

GREEN/YELLOW

BLUE or LABELLED - N

1. Decide on the position of your light fitting. Ensure there is a solid mounting surface, preferably a brick or block wall and ensure that there are no cables or pipes beneath the surface. If the wall is timber frame and plasterboard then please use appropriate fixings. Wall plugs are shown here – **Diagram A**. Ensure the fixings used can support the weight of the wall light.
2. Remove the fixing bracket, by undoing the 2 back plate /bracket screws (1), retain these for re-use.
3. Use the fixing bracket, as a template to mark the screw holes. Make sure the bracket is horizontal. Fix the bracket to the wall – the use of plugs (2) and screws (3) are shown here.
4. **Diagram B**. Support your fitting and connect the house wiring to the terminal block (4). **NOTE: This is a Class I fitting and must be earthed** – see wiring details.
5. Re-position the fitting over the wall bracket and secure with the 2 back plate / bracket screws (1), removed in 2 above. Make sure that all the internal cables and connections are inside the back plate taking care not to trap or strain the internal cables.
6. Fit the LED bulbs (5) into the lamp holders.
NOTE; Never fit bulbs of a higher wattage, or of a type other than those specified on the label (as these may cause overheating and damage the fitting).
7. Turn on the power and test.