

STEINEL Vertrieb GmbH
Dieselstraße 80-84
33442 Herzebrock-Clarholz
Tel: +49/5245/448-188
www.steinell.de



Contact
www.steinell.de/contact



110068831 11/2019_A Technische Änderungen vorbehalten. / Subject to technical modification without notice.

STEINEL®
Intelligent technology



CN BG RU LV LT EE HR SI RO PL SK CZ HU TR GR NO FI DK SE PT ES IT NL FR GB DE

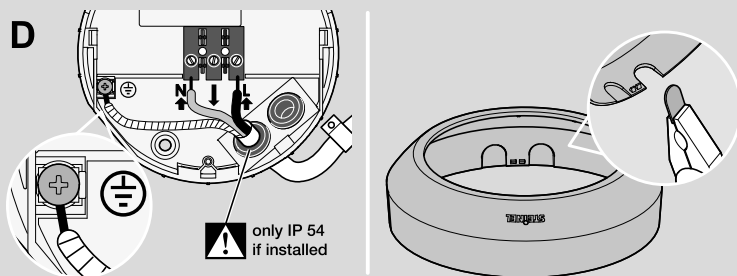
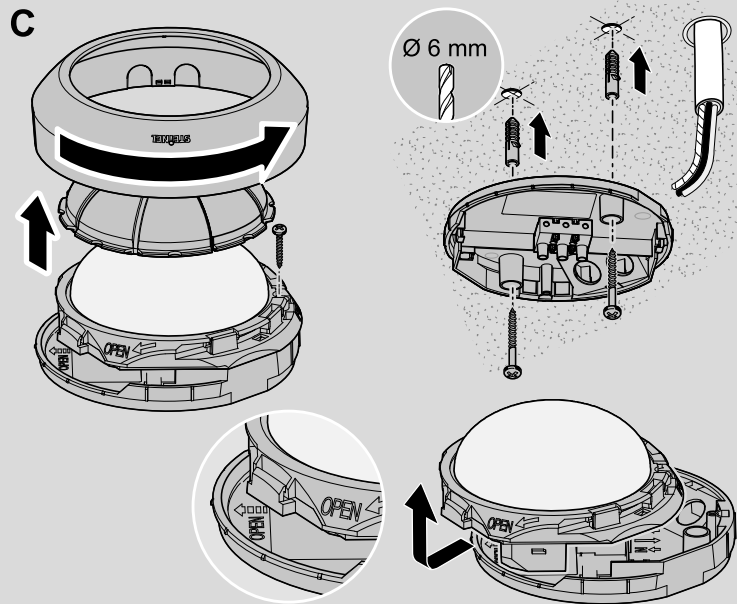
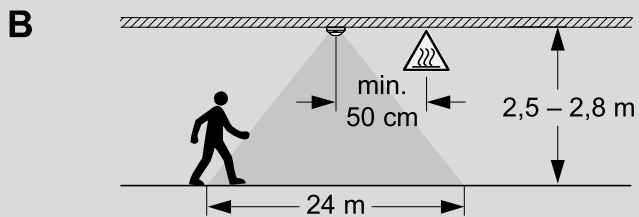
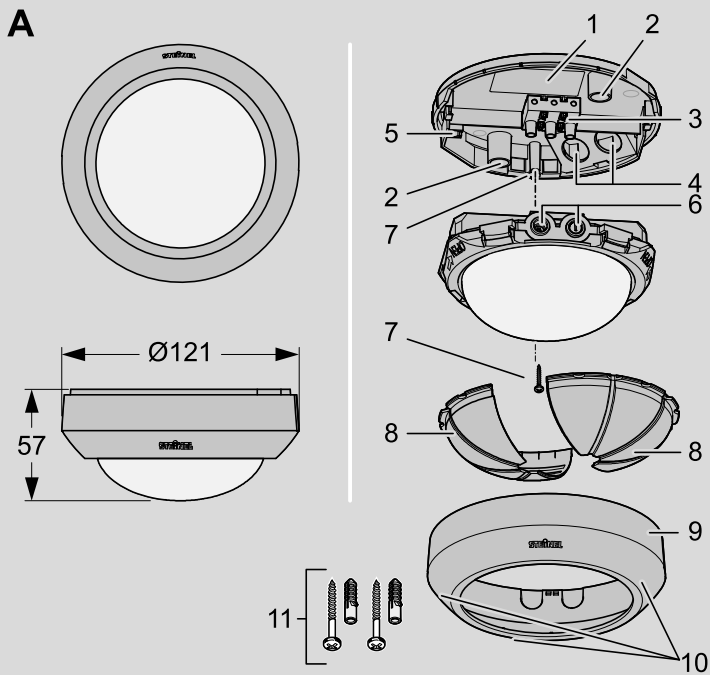

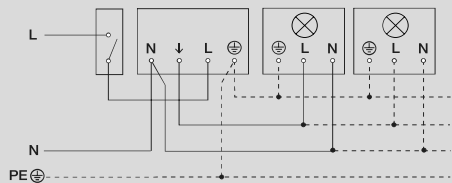
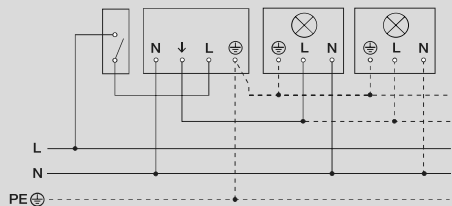
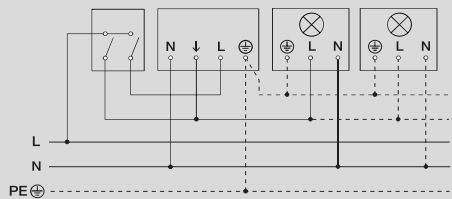
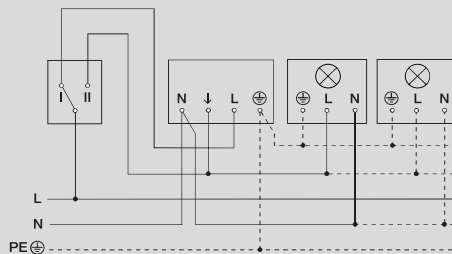
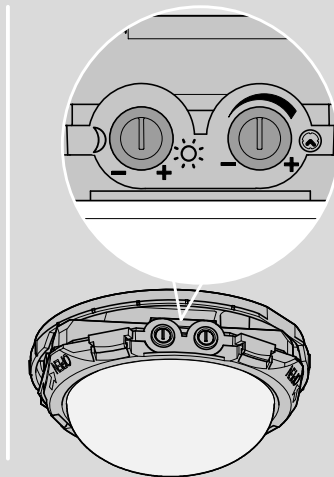
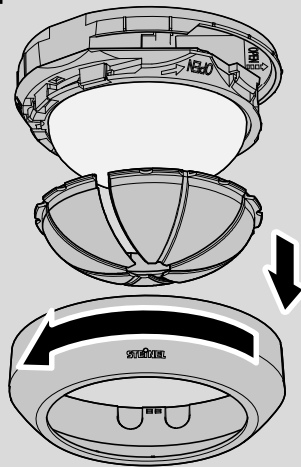
E**1****2****3****4****F**

5 sec – 15 min



2 – 1000 Lux

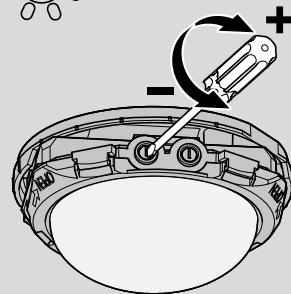
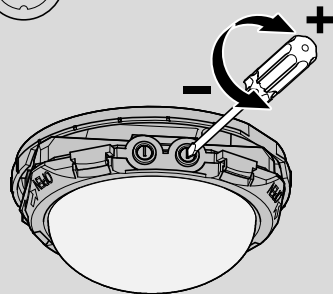

G

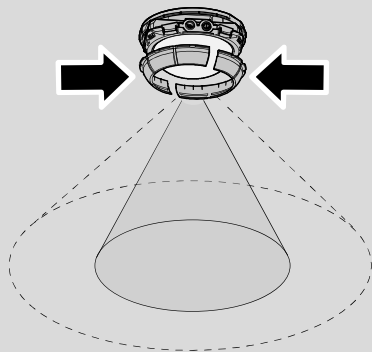
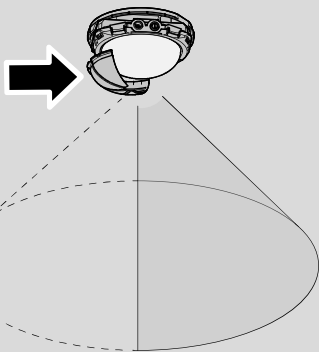
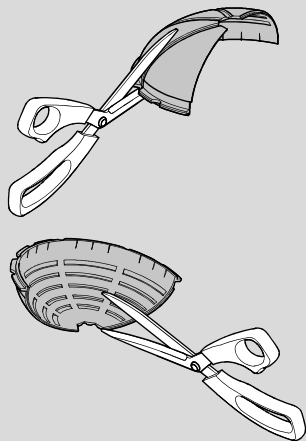
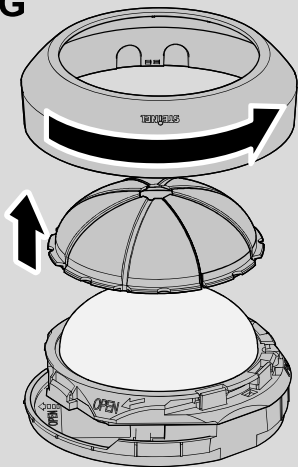

Montageanleitung

Zu dieser Anleitung

Handlungsanweisungen sind wie folgt gekennzeichnet:

- ▶ Handlungsanweisung

In den Sicherheitshinweisen geben das Warnsymbol und das Signalwort die Schwere der Gefahr an:

! Signalwort

Art und Quelle der Gefahr

Maßnahmen zur Gefahrenabwehr

- ▶ Lesen Sie diese Montageanleitung vor der Montage des Produkts.

Weiterführende Informationen

Weiterführende Informationen finden Sie auf der Webseite: www.steinel.de

Bestimmungsgemäßer Gebrauch

Der Außensensor IS 360-3 kann als Bewegungsmelder im Innen- und Außenbereich eingesetzt werden. Er erfasst mit drei Pyro-Sensoren die Wärmeabstrahlung sich bewegender Körper und schaltet angeschlossene Leuchten ein. Das Produkt ist ausschließlich für die Deckenmontage geeignet und darf nur gemäß der Angaben in den technischen Daten betrieben werden.

Alle Anschlussarbeiten an den elektrischen Anschlüssen dürfen nur von elektrotechnischem Fachpersonal gemäß der nationalen Bestimmungen durchgeführt werden.

Produktübersicht (Abb. A)

Halterung für die Deckenmontage

- 1 Typenschild
- 2 Bohrungen für Befestigung
- 3 Anschlüsse
 - N Neutralleiter
 - Pfeil Zuleitung für Leuchte
 - L Netzanschluss

- 4 Kabelführungen
- 5 Auflagepunkt für den Schutzleiter

Sensorgehäuse

- 6 zwei Einstellungsregler:
 - Ansprechschwelle und Nachlaufzeit
- 7 Gehäusebefestigung mit Schraube
- 8 Abdeckschalen
- 9 Abdeckring
- 10 Vorbohrungen für Entwässerung
- 11 Befestigungsmaterial

Lieferumfang und Produkt prüfen

- ▶ Prüfen Sie den Lieferumfang auf Vollständigkeit und das Produkt auf Unversehrtheit.
- ▶ Öffnen Sie das Gehäuse nicht, falls es beschädigt ist, reparieren Sie das Produkt nicht selbst.
- ▶ Verpacken Sie ein beschädigtes Produkt sorgfältig und senden Sie es mit einer kurzen Fehlerbeschreibung und einem Kaufnachweis (Rechnung) an eine Servicestation von Steinel.

Installation instructions

About these instructions

Instructions to take action are shown as follows:

- ▶ Instruction to take action

In the safety advice, the warning symbol and signal word indicate the severity of danger:



Signal word

Type and source of danger

Measures to avoid dangers

- ▶ Read these installation instructions before installing the product.

Further information

You will find further information at: www.steinel.de

Proper use

The IS 360-3 outdoor sensor can be used as an indoor and outdoor motion detector. Working with three pyro sensors, it detects heat radiated from moving objects and switches ON lights that are connected to it. The product is only suitable for installing on ceilings and may only be operated in line with the technical specifications.

All connecting work at the electrical connections may only be carried out by a qualified electrician and in compliance with national regulations.

Product parts (Fig. A)

Holder for ceiling mounting

- 1 Rating plate
- 2 Mounting holes
- 3 Connections
 - N neutral conductor
- Arrow** Power supply lead for light
- L Mains power supply
- 4 Cable entries
- 5 Contact point for protective-earth conductor

Sensor housing

- 6 two control dials:
 - Response threshold and stay-ON time
- 7 Housing attachment with screw
- 8 Shrouds
- 9 Cover ring
- 10 Pilot holes for drainage
- 11 Fixing material

Checking package contents and product

- ▶ Check to make sure that the product is complete and undamaged.
- ▶ Do not open the housing if it is damaged, and do not repair the product yourself.
- ▶ Carefully pack the damaged product and send it with a brief description of the fault and proof of purchase (in-voice) to a Steinel service station.

Preparing to install (Fig. B)

Defining point of installation

- ▶ Define the mounting position as follows:
 - Minimum distance of 50 cm from lights and other sources of heat
 - Unobstructed line of vision between the sensor and detection zone (obstacles include walls, glass panels, trees)
 - Mounting height of 2.50 m to 2.80 m for optimum reach

Planning usage



Caution

Risk of short-circuiting from overloading

When planning the number of lights to connect, always be sure **not to exceed the maximum switching capacity**, e.g. **2000 watts** for light bulbs, see section "Technical specifications".

Checking ambient conditions

If you are using the product in a very damp or humid environment:

- ▶ Drill drainage holes in the pilot holes (10) using a 5 mm drill bit

Installing (Fig. C)



Danger

Danger to life from touching live cables!

Disconnect cables from the power supply!

- ▶ Detach the cover ring (9) and the shrouds (8).
- ▶ Undo the housing attachment screw (7) and push it out of the holder.
- ▶ Drill holes at the intended mounting position.
- ▶ Attach the holder with the fixing material (11).

Connecting IS 360-3 (Fig. D)



Danger

Danger to life from electric shock!

All work at the connections may only be performed by a qualified electrician.

- ▶ Using a voltage tester, check to make sure that all cables are disconnected from the power supply.
- ▶ Thread the cables through the cable entries (4).
- ▶ Attach the PE conductor (yellow and green conductor) at the contact point (5).
- ▶ Connect the neutral conductor (blue or grey conductor) to the neutral conductor terminal **N**.
- ▶ Connect the live (black) conductor to the mains power supply terminal **L**.

Connecting power supply lead for lights

- ▶ Connect the power supply lead for light (brown) to the **arrow** terminal.

Note

Protection class IP54 is only ensured if the sealing plugs are fitted.

Connection examples (Fig. E)



Danger

Danger to life from electric shock!

All work at the connections may only be performed by a qualified electrician.

Connecting lights

- ▶ Connect lights that do not have a neutral conductor as shown in connection example 1.
- ▶ Connect lights that do have a neutral conductor as shown in connection example 2.

Installing two-circuit switch

If you want to switch OFF all connected lights via switch:

- ▶ install a two-circuit switch for manual and automatic operation (connection example 3).

Installing two-way switch

If you want to switch ON and OFF manually and also use sensor mode (automatic):

- ▶ Install a two-way switch (connection example 4).

Two-way switch options:

- **Position I** Sensor mode (switching ON and OFF automatically)
- **Position II** manual operating mode: switching ON and OFF via switch; after switching OFF, sensor mode is reactivated

Activating and deactivating manual override

A two-way switch provides a manual override function for lights connected.

To activate manual override:

- ▶ Turn the light switch to the OFF and ON positions twice in rapid succession (within less than half a second). Manual override keeps light ON permanently for four hours and then returns to sensor mode.

To deactivate manual override:

- ▶ Turn the light switch to the OFF and ON position once in rapid succession (within less than half a second). The light immediately switches to sensor mode.

Settings (Fig. F)

During installation or at a later time, you can infinitely adjust the stay-ON time and the response threshold via the control dials.

- ▶ Using a screwdriver, turn the control dials to the chosen positions:



Stay-ON time

+ maximum: 15 minutes

– minimum: 5 seconds

If you have set a stay-ON time of 15 minutes, the sensor will switch OFF the connected lights after 15 minutes.

If the sensor detects further movement, the stay-ON time will start from the beginning again.

Using the **response threshold**, you can infinitely adjust the level of ambient light at which the sensor switches on the lights connected.



Response threshold

+ maximum: 1000 lux

Daylight mode: the sensor switches light ON in daylight when it identifies a movement.



– minimum: 2 lux

Twilight setting: the sensor switches light ON at twilight. If the ambient brightness is brighter than 2 lux, the sensor does not switch light ON.

Detection zone (Fig. G)

Is the sensor switching light ON too often because it is being triggered by objects in the detection zone (e.g. in response to passing vehicles)? You can mask the sensor with shrouds (8) to restrict the detection zone.

- ▶ Detach the cover ring and the shrouds.
- ▶ Using a pair of scissors, cut the shrouds to size horizontally and/or vertically.
- ▶ Fit the shrouds to the sensor and, if necessary, adjust them to the appropriate position.
- ▶ Re-fit the cover ring.

Operation

Perform function test

- ▶ Set the response threshold to the current ambient brightness. The factory setting is daylight operation.
- ▶ Set the stay-ON time to a very short period. The factory setting is 5 seconds.
- ▶ Fit the sensor housing onto the holder and push it home until it clips into place.
- ▶ Tighten the housing attachment screw (7).
- ▶ Switch the power ON.
- ▶ Check whether the sensor responds to a movement and switches the light ON.

If it does, the sensor is ready for operation:

- ▶ Select your chosen settings and refit the cover ring (9).

If it does not:

- ▶ Check the connections and the voltage supply.

Troubleshooting



Danger

Danger to life from touching live components!

All work at the connections may only be performed by a qualified electrician. Disconnect cables from the power supply!

! Attention

Product damage from improper servicing

Servicing or repair work may only be performed by Steinel service stations.

Sensor will not switch ON

Either incorrect settings have been made, there is a power-related fault or the sensor is faulty:

- ▶ Check the setting for the response threshold and, if necessary, set a higher lux level.
- ▶ Check the cables, connections and the voltage supply, change a fuse if necessary.
- ▶ Carry out a function test on the sensor and on the lights connected, replacing any faulty items.

Sensor will not switch OFF

Either incorrect settings have been made, manual override is activated or there is permanent movement or a source of heat in the detection zone.

- ▶ Check whether the response threshold setting is too low, correcting the setting if necessary.
- ▶ Check whether the light has been switched ON manually via a switch.
- ▶ Check whether there are any sources of heat or anything else inadvertently triggering the sensor in the detection zone and remove them.
- ▶ If necessary, limit the detection zone with the shrouds.

Sensor switching ON when it should not

The sensor is detecting constant movement or a source of heat in the detection zone, causing it to switch ON too often or when it should not.

- ▶ Check the detection zone for sources of heat or movement.
- ▶ Eliminate permanent sources of heat from the detection zone.
- ▶ If necessary, limit the detection zone with the shrouds.

Disposal

Electrical and electronic equipment, accessories and packaging must be recycled in an environmentally compatible manner.



Do not dispose of electrical and electronic equipment as domestic waste.

EU countries only:

Under the current European Directive on Waste Electrical and Electronic Equipment and its implementation in national law, electrical and electronic equipment no longer suitable for use must be collected separately and recycled in an environmentally compatible manner.

Warranty

3 YEAR
MANUFACTURER'S
WARRANTY

Steinel provides a 3-year warranty from the date of purchase for defects caused by material flaws or manufacturing faults.

Once the warranty expires, Steinel provides a repair service at its service stations via the factory service.

Service

- ▶ Contact the service stations through your country's branch of Steinel Vertrieb GmbH. You will find contact details on the back of these instructions.

Technical specifications

Dimensions and versions

Ø × height	121 mm × 57 mm
Colours	white, black

Specifications

Supply voltage	220 – 240 V
Mains frequency	50/60 Hz
Additional switching capacities	
Incandescent / halogen lamp load	2000 W
Fluorescent lamps, electronic ballast	1500 W
Fluorescent lamps, uncorrected	500 VA
Fluorescent lamps, series-corrected	900 VA
Fluorescent lamps, parallel-corrected	400 VA
Low-voltage halogen lamps	2000 VA
LED < 2 W	100 W
2 W < LED < 8 W	300 W
LED > 8 W	600 W
Capacitive load	176 µF

Sensor

Sensor technology	Passive infrared, 3 pyro sensors
Angle of coverage	360°
Angle of aperture	90°
Sneak-by guard	provided

Reach and settings

Detection zone and reach	12 m, at a mounting height of 2.50 m to 2,80 m
Switching ON at threshold levels	2 lux to 1000 lux, (daylight operation)
Stay-ON time, continuously variable	5 seconds to 15 minutes

Environment

IP rating	IP54
Temperature range	−20°C to +50°C